

www.timprocess.com
info@timprocess.com

Raccords double bague inox





2	SOMMAIRE
4	INFORMATIONS
5	RACCORDS UNION DROIT
7	CONNECTEURS MÂLES
11	CONNECTEURS MALES A SOUDER
12	CONNECTEURS FEMELLES
15	REDUCTEURS
17	EMBOUTS ET BOUCHONS
19	COUDES 90°
22	COUDES 90° A SOUDER
22	COUDES 45°
23	TES
25	CROIX
25	ADAPATEURS MÂLES
27	ADAPTATEURS FEMELLES
30	PIECES DE RECHANGES



GAZ MEDICAUX
FLUIDES INDUSTRIELS
GAZ COMBURANTS
GAZ COMBUSTIBLES
GAZ SPECIAUX









Navigation simplifiée sur catalogue PDF, Cliquez !



SOMMAIRE



INFORMATIONS			
Code couleurs		4	Filetages et étanchéités par bague BS ou joints plats
Codification des dimensions		4	



RACCORDS UNIONS DROIT			
Union simple		5	Union passage de cloison
Union métrique à fractionnaire		5	Union passage de cloison réducteur
Union réducteur		6	Union passage de cloison métrique à fractionnaire

CONNECTEURS MÂLES			
Connecteur métrique NPT mâle		7	Connecteur mâle NPT passage de cloison
Connecteur fractionnaire NPT mâle		7	Connecteur mâle SAE / MS
Connecteur Gaz conique mâle (ISO)		8	Connecteur mâle AN
Connecteur Gaz cylindrique mâle « S » (ISO)		9	Connecteur mâle AN passage de cloison
Connecteur Gaz cylindrique mâle « E » (ISO)		9	Connecteur mâle SAE / MS

CONNECTEURS MÂLES A SOUDER			
Connecteur à souder OD SW		11	Connecteur à souder pipe BW

CONNECTEURS FEMELLES			
Connecteur NPT femelle		12	Connecteur femelle cylindrique « E »
Connecteur femelle Gaz conique		12	Connecteur femelle cylindrique « M » (manomètre)
Connecteur femelle cylindrique « I »		13	Connecteur femelle NPT passage cloison

REDUCTEURS			
Réducteur métrique		15	Réducteur fractionnaire à métrique
Réducteur fractionnaire		15	Réducteur passage de cloison
Réducteur métrique à fractionnaire		16	

EMBOUTS ET BOUCHONS			
Embout de raccordement		17	Bouchon
Embout de raccordement réducteur		17	Event
Capuchon		18	



COUDES 90°

Coude 90° union			19	Coude 90° mâle réducteur			21
Coude 90° métrique NPT mâle			19	Coude 90° mâle PR			21
Coude 90° fractionnaire NPT mâle			20	Coude 90° mâle ST			21
Coude 90° mâle Gaz conique			20	Coude 90° femelle NPT			39

COUDES A SOUDER

Coude 90° à souder tube OD SW			22	Coude 90° à souder pipe BW			22
-------------------------------	--	--	----	----------------------------	--	--	----

COUDES A 45°

Coude 45° mâle NPT			22	Coude 45° mâle SAE/MS			22
--------------------	--	--	----	-----------------------	--	--	----

TES

Té union			23	Té NPT mâle			24
Té réducteur métrique			23	Té mâle SAE MS TTR TTS TRT TFT			24
Té réducteur fractionnaire			23	Té femelle NPT			24
Té réducteur spécial			24				

CROIX

Croix			25
-------	--	--	----

ADAPTATEURS MÂLES

Adaptateur pour tube NPT mâle			25	Adaptateur pour tube Gaz cylindrique mâle « E »			27
Adaptateur pour tube Gaz conique mâle			26	Adaptateur pour tube ST SAE MS AN mâle			27
Adaptateur pour tube Gaz cylindrique mâle « S »			26	Adaptateur pour tube mâle à souder			27

ADAPTATEURS FEMELLES

Adaptateur pour tube femelle NPT			27	Adaptateur pour tube femelle Gaz cylindrique « M »			29
Adaptateur pour tube femelle Gaz conique			28	Adaptateur pour tube femelle Gaz cylindrique « I »			29
Adaptateur pour tube femelle Gaz cylindrique « S »			28	Adaptateur pour tube femelle AN			30

PIECES DE RECHANGES

Ecrou			30	Kit bague avant + bague arrière			32
Ecrou mâle			30	Kit écrou + bague avant + bague arrière			32
Bague avant			31	Joints S / E / M / I			33
Bague arrière			31				

INFORMATIONS

Code couleurs



Afin de repérer rapidement les références que vous recherchez, nous avons établi un code à 3 couleurs :

Code couleurs des tableaux	Types
Vert	Dimension métrique
Orange	Dimension fractionnaire
Bleu	Dimension mixte métrique et fractionnaire

Codification des dimensions

Dimensions métriques (mm)	Code
2	02
3	03
4	04
6	06
8	08
10	10
12	12
14	14
15	15
16	16
18	18
20	20
22	22
25	25
28	28
30	30
32	32
38	38
50	50

Dimensions fractionnaires (pouce)	Code
1/16"	51
1/8"	52
3/16"	53
1/4"	54
5/16"	55
3/8"	56
1/2"	57
5/8"	58
3/4"	59
7/8"	60
1"	61
1" 1/8	62
1" 1/4	63
1" 1/2	64
2"	65

Filetages et étanchéités par bague BS ou joints plats



Vous trouverez ci-dessous un mémorandum technique concernant les différents types d'étanchéités pour raccord à filetage cylindrique de type Gaz (ISO).

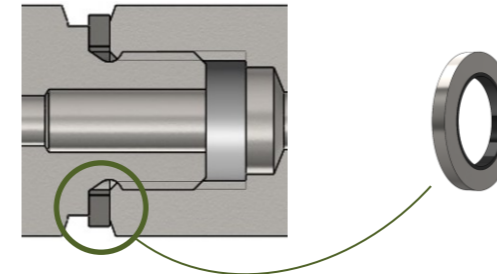

TYPE « S »

L'étanchéité est réalisée par une bague « BS », une bague surmoulée en d'un élastomère. Voir page 33 pour les références de joint.

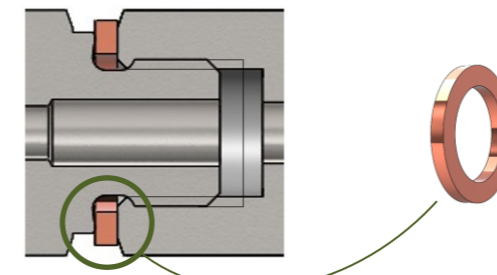

TYPE « E »

L'étanchéité est réalisée par un joint plat en cuivre sur la face externe du raccord femelle. Voir page 33 pour les références de joint.

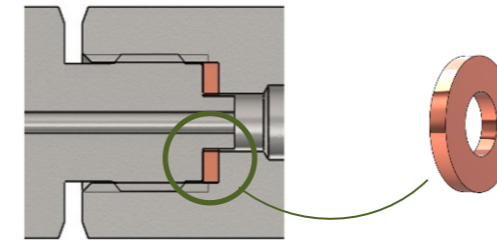

TYPE « M »

L'étanchéité est réalisée par un joint plat en cuivre sur la face interne du raccord femelle. Voir page 33 pour les références de joint.

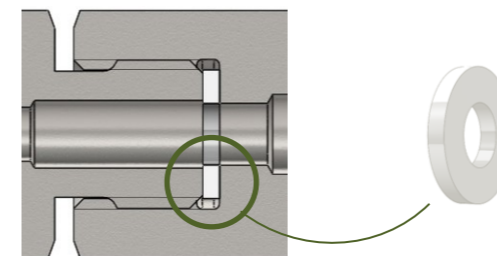

TYPE « I »

L'étanchéité est réalisée par un joint plat en polymère sur la face interne du raccord femelle. Voir page 33 pour les références de joint.

RACCORDS UNION DROIT

10 01 Union simple



	ØA (mm)	Référence article
Dimensions métriques	2	10 01 0202
	3	10 01 0303
	4	10 01 0404
	6	10 01 0606
	8	10 01 0808
	10	10 01 1010
	12	10 01 1212
	14	10 01 1414
	15	10 01 1515
	16	10 01 1616
	18	10 01 1818
	20	10 01 2020
	22	10 01 2222
	25	10 01 2525
	28	10 01 2828
	30	10 01 3030
32	10 01 3232	
38	10 01 3838	
50	10 01 5050	

	ØA (pouce)	Référence article
Dimensions fractionnaires	1/16"	10 01 5151
	1/8"	10 01 5252
	3/16"	10 01 5353
	1/4"	10 01 5454
	5/16"	10 01 5555
	3/8"	10 01 5656
	1/2"	10 01 5757
	5/8"	10 01 5858
	3/4"	10 01 5959
	7/8"	10 01 6060
	1"	10 01 6161
	1"1/8	10 01 6262
	1"1/4	10 01 6363
	1"1/2	10 01 6464
2"	10 01 6565	

10 02 Union métrique à fractionnaire



	ØA (mm)	ØB (pouce)	Référence article
Dimensions métriques à fractionnaires	2	1/8"	10 02 0252
		1/4"	10 02 0254
	3	1/8"	10 02 0352
		1/4"	10 02 0452
	4	1/8"	10 02 0452
		1/4"	10 02 0454
	6	1/16"	10 02 0651
		1/8"	10 02 0652
		1/4"	10 02 0654
		5/16"	10 02 0655
	8	3/8"	10 02 0656
		1/4"	10 02 0854
		3/8"	10 02 0856
	10	1/8"	10 02 1052
		1/4"	10 02 1054
		5/16"	10 02 1055
		3/8"	10 02 1056
	12	1/4"	10 02 1254
		5/16"	10 02 1255
		3/8"	10 02 1256
		1/2"	10 02 1257
	15	1/2"	10 02 1557
	16	5/8"	10 02 1658
	18	3/4"	10 02 1859
20	1/2"	10 02 2057	
	1"	10 02 2061	
25	1"	10 02 2561	

10 03 Union réducteur

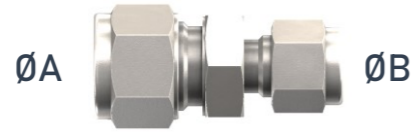

	ØA (mm)	ØB (mm)	Référence article
Dimensions métriques	3	2	10 03 0302
	6	2	10 03 0602
		3	10 03 0603
		4	10 03 0604
	8	6	10 03 0806
	10	6	10 03 1006
		8	10 03 1008
	12	6	10 03 1206
		8	10 03 1208
		10	10 03 1210
	16	10	10 03 1610
		12	10 03 1612
	18	12	10 03 1812
	25	18	10 03 2518
		20	10 03 2520
	30	18	10 03 3018
		20	10 03 3020
		25	10 03 3025
	32	18	10 03 3218
		20	10 03 3220
25		10 03 3225	
38	20	10 03 3820	
	25	10 03 3825	
		30	10 03 3830

	ØA (pouce)	ØB (pouce)	Référence article
Dimensions fractionnaires	1/8"	1/16"	10 03 5251
	3/16"	1/16"	10 03 5351
		1/8"	10 03 5352
	1/4"	1/16"	10 03 5451
		1/8"	10 03 5452
	5/16"	3/16"	10 03 5453
		1/8"	10 03 5552
	3/8"	1/4"	10 03 5554
		1/16"	10 03 5651
		1/8"	10 03 5652
		1/4"	10 03 5654
	1/2"	5/16"	10 03 5655
		1/8"	10 03 5752
		1/4"	10 03 5754
	5/8"	3/8"	10 03 5756
		1/2"	10 03 5856
		1/4"	10 03 5857
	3/4"	1/4"	10 03 5954
		3/8"	10 03 5956
		1/2"	10 03 5957
	1"	5/8"	10 03 5958
		1/2"	10 03 6157
		3/4"	10 03 6159

10 04 Union passage de cloison

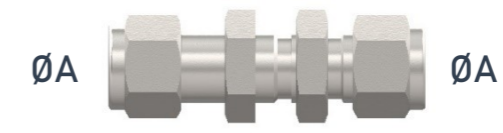

	ØA (mm)	Référence article
Dimensions métriques	3	10 04 0303
	4	10 04 0404
	6	10 04 0606
	8	10 04 0808
	10	10 04 1010
	12	10 04 1212
	14	10 04 1414
	15	10 04 1515
	16	10 04 1616
	18	10 04 1818
	20	10 04 2020
	25	10 04 2525
	30	10 04 3030
	32	10 04 3232
	38	10 04 3838

	ØA (pouce)	Référence article
Dimensions fractionnaires	1/16"	10 04 5151
	1/8"	10 04 5252
	3/16"	10 04 5353
	1/4"	10 04 5454
	5/16"	10 04 5555
	3/8"	10 04 5656
	1/2"	10 04 5757
	5/8"	10 04 5858
	3/4"	10 04 5959
	1"	10 04 6161
	1"1/4"	10 04 6363
	1"1/2"	10 04 6464
	2"	10 04 6565

CONNECTEURS MÂLES

10 05 Union passage de cloison réducteur

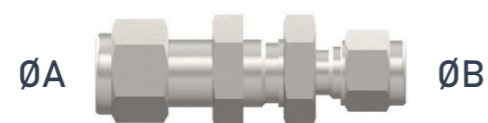

	ØA (pouce)	ØB (pouce)	Référence article
Dimensions fractionnaires	1/4"	1/8"	10 05 5452
	3/8"	1/4"	10 05 5654
	1/2"	1/4"	10 05 5754

10 06 Union passage de cloison métrique à fractionnaire



	ØA (mm)	ØB (pouce)	Référence article
Dimensions métriques / fractionnaires	6	1/8"	10 06 0652

10 07 Connecteur métrique NPT mâle



	ØA (mm)	ØB Filetage	Référence article
Dimensions métriques	2	1/8"	10 07 0252
	3	1/8"	10 07 0352
		1/4"	10 07 0354
	4	1/8"	10 07 0452
		1/4"	10 07 0454
	6	1/8"	10 07 0652
		1/4"	10 07 0654
		3/8"	10 07 0656
		1/2"	10 07 0657
	8	1/8"	10 07 0852
		1/4"	10 07 0854
		3/8"	10 07 0856
		1/2"	10 07 0857
	10	1/8"	10 07 1052
		1/4"	10 07 1054
		3/8"	10 07 1056
		1/2"	10 07 1057
		3/4"	10 07 1059
	12	1/8"	10 07 1252
		1/4"	10 07 1254
3/8"		10 07 1256	
1/2"		10 07 1257	
14	3/4"	10 07 1259	
	1/4"	10 07 1454	
	3/8"	10 07 1456	
15	1/2"	10 07 1457	
	1/2"	10 07 1557	
16	3/8"	10 07 1656	
	1/2"	10 07 1657	
	3/4"	10 07 1659	
18	1/2"	10 07 1857	
	3/4"	10 07 1859	

	ØA (mm)	ØB Filetage	Référence article
Dimensions métriques	20	1/2"	10 07 2057
		3/4"	10 07 2059
	22	3/4"	10 07 2259
		1"	10 07 2261
	25	1/2"	10 07 2557
		3/4"	10 07 2559
		1"	10 07 2561
	28	1"	10 07 2861
		1"1/4"	10 07 2863
	30	1"1/4"	10 07 3063
	32	1"1/4"	10 07 3263
	38	1"1/2"	10 07 3864

10 07 Connecteur fractionnaire NPT mâle



	ØA (pouce)	ØB Filetage	Référence article
Dimensions fractionnaires	1/16"	1/16"	10 07 5151
		1/8"	10 07 5152
		1/4"	10 07 5154
	1/8"	1/16"	10 07 5251
		1/8"	10 07 5252
		1/4"	10 07 5254
		3/8"	10 07 5256
	3/16"	1/2"	10 07 5257
		1/8"	10 07 5352
	3/16"	1/4"	10 07 5354
		1/16"	10 07 5451
	1/4"	1/8"	10 07 5452
		1/4"	10 07 5454
		3/8"	10 07 5456
		1/2"	10 07 5457
		3/4"	10 07 5459
		5/16"	1/8"
	5/16"	1/4"	10 07 5554
		3/8"	10 07 5556
	3/8"	1/8"	10 07 5652
		1/4"	10 07 5654
		3/8"	10 07 5656
		1/2"	10 07 5657
		3/4"	10 07 5659
		1"	10 07 5661
	1/2"	1/8"	10 07 5752
		1/4"	10 07 5754
		3/8"	10 07 5756
1/2"		10 07 5757	
3/4"		10 07 5759	
1"	10 07 5761		

	ØA (pouce)	ØB Filetage	Référence article
Dimensions fractionnaires	5/8"	1/4"	10 07 5854
		3/8"	10 07 5856
		1/2"	10 07 5857
		3/4"	10 07 5859
	3/4"	3/8"	10 07 5956
		1/2"	10 07 5957
		3/4"	10 07 5959
		1"	10 07 5961
	7/8"	1/2"	10 07 6057
		3/4"	10 07 6059
	7/8"	1"	10 07 6061
		1"	10 07 6157
	1"	3/4"	10 07 6159
		1"	10 07 6161
	1"1/8"	1"	10 07 6261
	1"1/4"	1"	10 07 6361
		1"1/4"	10 07 6363
	1"1/2"	1"1/2"	10 07 6464
		2"	10 07 6565

10 08 Connecteur Gaz conique mâle (ISO)



	ØA (mm)	ØB Filetage	Référence article
Dimensions métriques	2	1/8"	10 08 0252
	3	1/8"	10 08 0352
		1/4"	10 08 0354
	4	1/8"	10 08 0452
		1/4"	10 08 0454
	6	1/8"	10 08 0652
		1/4"	10 08 0654
		3/8"	10 08 0656
		1/2"	10 08 0657
	8	1/8"	10 08 0852
		1/4"	10 08 0854
		3/8"	10 08 0856
		1/2"	10 08 0857
	10	1/8"	10 08 1052
		1/4"	10 08 1054
		3/8"	10 08 1056
		1/2"	10 08 1057
	12	3/4"	10 08 1059
		1/4"	10 08 1254
		3/8"	10 08 1256
		1/2"	10 08 1257
	14	3/4"	10 08 1259
		1/4"	10 08 1454
	15	3/8"	10 08 1456
		1/2"	10 08 1557
	16	1/4"	10 08 1654
		3/8"	10 08 1656
		1/2"	10 08 1657
18	3/4"	10 08 1659	
	1/2"	10 08 1857	
20	3/4"	10 08 1859	
	1/2"	10 08 2057	
20	3/4"	10 08 2059	

	ØA (mm)	ØB Filetage	Référence article
Dimensions métriques	22	3/4"	10 08 2259
		1"	10 08 2261
	25	1/2"	10 08 2557
		3/4"	10 08 2559
	28	1"	10 08 2561
		1"1/4"	10 08 2861
	30	1"1/4"	10 08 2863
		1"1/4"	10 08 3063
	32	1"1/4"	10 08 3263
		1"1/2"	10 08 3864
Dimensions fractionnaires	1/8"	1/8"	10 08 5252
		1/4"	10 08 5254
	1/4"	1/8"	10 08 5452
		1/4"	10 08 5454
		3/8"	10 08 5456
	5/16"	1/2"	10 08 5457
		1/8"	10 08 5552
		1/4"	10 08 5554
	3/8"	1/8"	10 08 5652
		1/4"	10 08 5654
		3/8"	10 08 5656
		1/2"	10 08 5657
	1/2"	3/4"	10 08 5659
		1/4"	10 08 5754
		3/8"	10 08 5756
		1/2"	10 08 5757
	5/8"	3/4"	10 08 5759
		1/2"	10 08 5857
3/4"		10 08 5959	
3/4"	1"	10 08 5961	
	3/4"	10 08 6159	
1"	1"	10 08 6161	

10 09 Connecteur Gaz cylindrique mâle « S » (ISO)

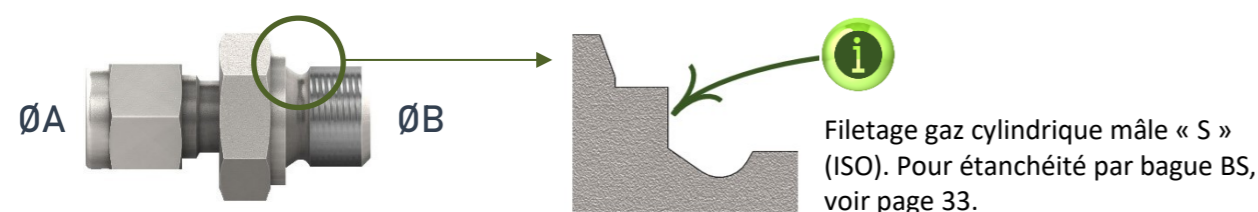

ØA (mm)	ØB Filetage	Référence article
2	1/8"	10 09 0252
3	1/8"	10 09 0352
	1/4"	10 09 0354
4	1/8"	10 09 0452
6	1/8"	10 09 0652
	1/4"	10 09 0654
	3/8"	10 09 0656
	1/2"	10 09 0657
8	1/8"	10 09 0852
	1/4"	10 09 0854
	3/8"	10 09 0856
	1/2"	10 09 0857
10	1/4"	10 09 1054
	3/8"	10 09 1056
	1/2"	10 09 1057
12	1/4"	10 09 1254
	3/8"	10 09 1256
	1/2"	10 09 1257
14	3/8"	10 09 1456
	1/2"	10 09 1457
15	3/8"	10 09 1556
	1/2"	10 09 1557
	3/4"	10 09 1559
16	3/8"	10 09 1656
	1/2"	10 09 1657
18	3/4"	10 09 1659
	1/2"	10 09 1857
20	3/4"	10 09 1859
	1/2"	10 09 2057
	3/4"	10 09 2059

ØA	ØB Filetage	Référence article
22	3/4"	10 09 2259
	1"	10 09 2261
25	3/4"	10 09 2559
	1"	10 09 2561
28	1"	10 09 2861
	1"1/4	10 09 2863
30	1"1/4	10 09 3063
32	1"1/4	10 09 3263
38	1"1/2	10 09 3864
1/8"	1/8"	10 09 5252
	1/4"	10 09 5254
	3/8"	10 09 5256
1/4"	1/8"	10 09 5452
	1/4"	10 09 5454
	3/8"	10 09 5456
3/8"	1/2"	10 09 5457
	1/8"	10 09 5652
	1/4"	10 09 5654
1/2"	3/8"	10 09 5656
	1/2"	10 09 5657
	1/4"	10 09 5754
3/4"	3/8"	10 09 5756
	1/2"	10 09 5757
1"	1/2"	10 09 5957
	3/4"	10 09 5959
1"	1/2"	10 09 6157
	3/4"	10 09 6159
	1"	10 09 6161

10 10 Connecteur Gaz cylindrique mâle « E » (ISO)

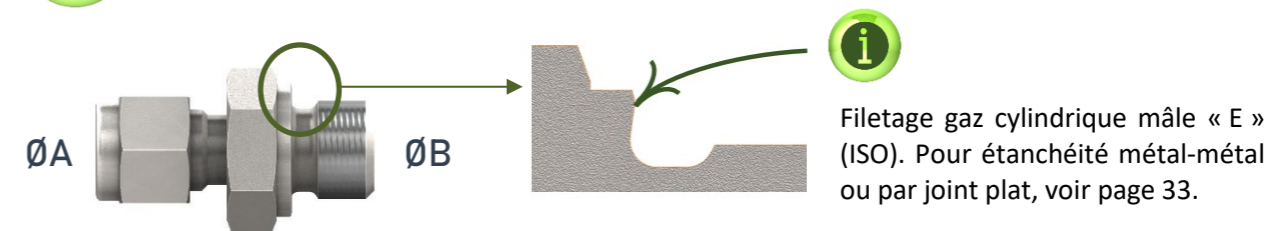

ØA (mm)	ØB Filetage	Référence article
3	1/8"	10 10 0352
	1/4"	10 10 0354
4	1/8"	10 10 0452
6	1/8"	10 10 0652
	1/4"	10 10 0654
	3/8"	10 10 0656
	1/2"	10 10 0657
8	1/8"	10 10 0852
	1/4"	10 10 0854
	3/8"	10 10 0856
10	1/2"	10 10 0857
	1/4"	10 10 1054
	3/8"	10 10 1056
12	1/2"	10 10 1057
	1/4"	10 10 1254
	3/8"	10 10 1256
15	1/2"	10 10 1257
	3/4"	10 10 1259
	1/2"	10 10 1557
16	3/8"	10 10 1656
	1/2"	10 10 1657
18	1/2"	10 10 1857
	3/4"	10 10 1859
20	1/2"	10 10 2057
	3/4"	10 10 2059
22	3/4"	10 10 2259
	1"	10 10 2261

ØA	ØB Filetage	Référence article
25	3/4"	10 10 2559
	1"	10 10 2561
28	1"	10 10 2861
	1"1/4	10 10 2863
30	1"1/4	10 10 3063
32	1"1/4	10 10 3263
38	1"1/2	10 10 3864
1/8"	1/8"	10 10 5252
	1/4"	10 10 5254
1/4"	1/8"	10 10 5452
	1/4"	10 10 5454
1/2"	3/8"	10 10 5756
	1/2"	10 10 5757
3/4"	1/2"	10 10 5957
	3/4"	10 10 5959
1"	1"	10 10 6161

10 11 Connecteur mâle NPT passage de cloison

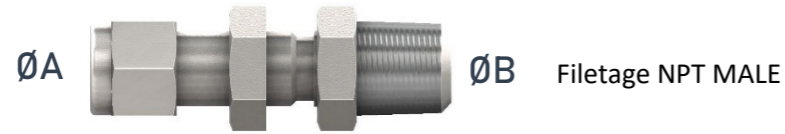

	ØA	ØB Filetage	Référence article
Dim. Métr.	6	1/8"	10 11 0652
		1/4"	10 11 0654
Dimensions fractionnaires	12	1/2"	10 11 1257
	1/8"	1/8"	10 11 5252
		1/4"	10 11 5452
	1/4"	1/8"	10 11 5452
		1/4"	10 11 5454
	3/8"	1/4"	10 11 5654
		3/8"	10 11 5656
		1/2"	10 11 5657
	1/2"	3/8"	10 11 5756
		1/2"	10 11 5757
3/4"	3/4"	10 11 5959	
1"	1"	10 11 6161	

10 12 Connecteur mâle SAE / MS

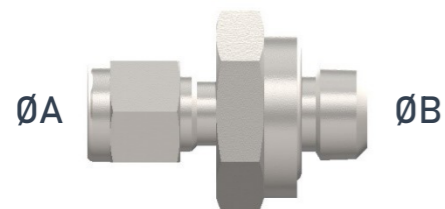

Composants sur demande

10 13 Connecteur mâle AN

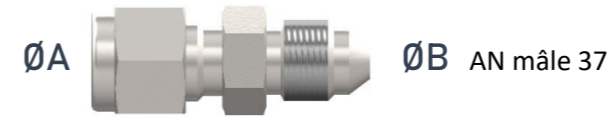

	ØA (pouce)	ØB AN	Référence article
Dimensions fractionnaires	1/16"	1/8"	10 13 5152
	1/8"	1/8"	10 13 5252
		1/4"	10 13 5254
	1/4"	1/4"	10 13 5454
	5/16"	5/16"	10 13 5555
	3/8"	1/4"	10 13 5654
		3/8"	10 13 5656
	1/2"	1/2"	10 13 5757
	3/4"	3/4"	10 13 5959
	1"	1"	10 13 6161

10 14 Connecteur mâle AN passage de cloison

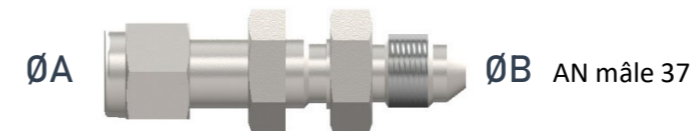

	ØA (pouce)	ØB AN	Référence article
Dimensions fractionnaires	1/4"	1/4"	10 14 5454
	3/8"	3/8"	10 14 5656
	1/2"	1/2"	10 14 5757
	3/4"	3/4"	10 14 5959
	1"	1"	10 14 6161

10 15 Connecteur mâle SAE / MS

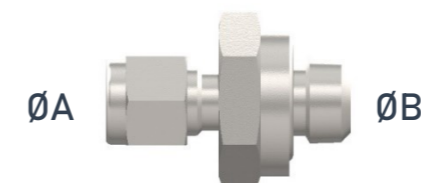

Composants sur demande

CONNECTEURS MALES A SOUDER

10 16 Connecteur à souder OD SW



	ØA (pouce)	ØB à souder Tube OD SW	Référence article
Dimensions fractionnaires	1/8"	1/8"	10 16 5252
	1/4"	1/4"	10 16 5454
	3/8"	3/8"	10 16 5656
	1/2"	1/2"	10 16 5757
	3/4"	3/4"	10 16 5959
	1"	1"	10 16 6161

10 17 Connecteur à souder pipe BW

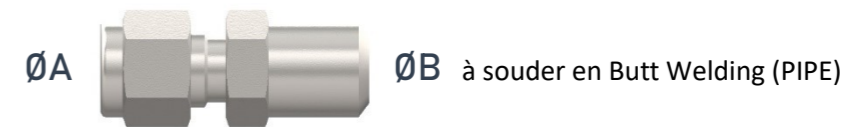

	ØA (mm)	ØB à souder pipe BW	Référence article
Dimensions métriques	3	1/8"	10 17 0352
	4	1/8"	10 17 0452
	6	1/8"	10 17 0652
		1/4"	10 17 0654
	8	1/8"	10 17 0852
		1/4"	10 17 0854
		1/2"	10 17 0857
	10	1/4"	10 17 1054
		3/8"	10 17 1056
		1/2"	10 17 1057
	12	1/4"	10 17 1254
		3/8"	10 17 1256
		1/2"	10 17 1257
	14	3/8"	10 17 1456
	15	1/2"	10 17 1557
	16	1/2"	10 17 1657
18	1/2"	10 17 1857	
30	1"1/4	10 17 3063	
32	1"1/4	10 17 3263	
38	1"1/2	10 17 3864	

	ØA (pouce)	ØB à souder pipe BW	Référence article
Dimensions fractionnaires	1/8"	1/8"	10 17 5252
	3/16"	1/8"	10 17 5352
	1/4"	1/8"	10 17 5452
		1/4"	10 17 5454
	5/16"	1/8"	10 17 5552
		1/4"	10 17 5554
	3/8"	1/4"	10 17 5654
		3/8"	10 17 5656
		1/2"	10 17 5657
		3/4"	10 17 5659
	1/2"	3/8"	10 17 5756
		1/2"	10 17 5757
		3/4"	10 17 5759
		1"	10 17 5761
	5/8"	1/2"	10 17 5857
	3/4"	1/2"	10 17 5957
		3/4"	10 17 5959
	1"	1"	10 17 6161
	1"1/4	1"1/4	10 17 6363
	1"1/2	1"1/2	10 17 6464
2"	2"	10 17 6565	

CONNECTEURS FEMELLES

10 18 Connecteur NPT femelle



10 19 Connecteur femelle Gaz conique



	ØA (mm)	ØB Filetage	Référence article
Dimensions métriques	3	1/8"	10 18 0352
		1/4"	10 18 0354
	4	1/8"	10 18 0452
		1/8"	10 18 0652
	6	1/4"	10 18 0654
		3/8"	10 18 0656
		1/2"	10 18 0657
	8	1/8"	10 18 0852
		1/4"	10 18 0854
		3/8"	10 18 0856
		1/2"	10 18 0857
	10	1/4"	10 18 1054
		3/8"	10 18 1056
		1/2"	10 18 1057
	12	1/4"	10 18 1254
		3/8"	10 18 1256
		1/2"	10 18 1257
	15	1/2"	10 18 1557
	16	1/2"	10 18 1657
	20	1/2"	10 18 2057
3/4"		10 18 2059	
22	3/4"	10 18 2259	
	1"	10 18 2261	
25	3/4"	10 18 2559	
	1"	10 18 2561	

	ØA (pouce)	ØB Filetage	Référence article
Dimensions fractionnaires	1/16"	1/16"	10 18 5151
		1/8"	10 18 5152
	1/8"	1/8"	10 18 5252
		1/4"	10 18 5254
	3/16"	1/8"	10 18 5352
		1/8"	10 18 5452
	1/4"	1/4"	10 18 5454
		3/8"	10 18 5456
		1/2"	10 18 5457
	5/16"	1/8"	10 18 5552
		1/4"	10 18 5554
	3/8"	1/8"	10 18 5652
		1/4"	10 18 5654
		3/8"	10 18 5656
		1/2"	10 18 5657
		3/4"	10 18 5659
	1/2"	1/4"	10 18 5754
		3/8"	10 18 5756
		1/2"	10 18 5757
		3/4"	10 18 5759
	5/8"	3/8"	10 18 5856
		1/2"	10 18 5857
		3/4"	10 18 5859
	3/4"	1/2"	10 18 5957
		3/4"	10 18 5959
	7/8"	3/4"	10 18 6059
	1"	3/4"	10 18 6159
		1"	10 18 6161
	1"1/4	1"1/4	10 18 6363
	1"1/2	1"1/2	10 18 6464
2"	2"	10 18 6565	

	ØA (mm)	ØB Filetage	Référence article
Dimensions métriques	3	1/8"	10 19 0352
	6	1/8"	10 19 0652
		1/4"	10 19 0654
		3/8"	10 19 0656
	8	1/2"	10 19 0657
		1/8"	10 19 0852
		1/4"	10 19 0854
	10	3/8"	10 19 0856
		1/2"	10 19 0857
		1/8"	10 19 1052
		1/4"	10 19 1054
	12	3/8"	10 19 1056
		1/2"	10 19 1057
		1/8"	10 19 1252
		1/4"	10 19 1254
		3/8"	10 19 1256
	15	1/2"	10 19 1257
		3/4"	10 19 1259
		3/8"	10 19 1556
	20	1/2"	10 19 1557
1/2"		10 19 2057	
22	3/4"	10 19 2059	
	3/4"	10 19 2259	
25	1"	10 19 2261	
	3/4"	10 19 2559	
1"	10 19 2561		

	ØA (pouce)	ØB Filetage	Référence article
Dimensions fractionnaires	1/8"	1/8"	10 19 5252
	1/4"	1/8"	10 19 5452
		1/4"	10 19 5454
		3/8"	10 19 5456
	3/8"	1/2"	10 19 5457
		1/4"	10 19 5654
		3/8"	10 19 5656
		1/2"	10 19 5657
	1/2"	1/4"	10 19 5754
		3/8"	10 19 5756
1/2"		10 19 5757	

10 20 Connecteur femelle cylindrique « I »

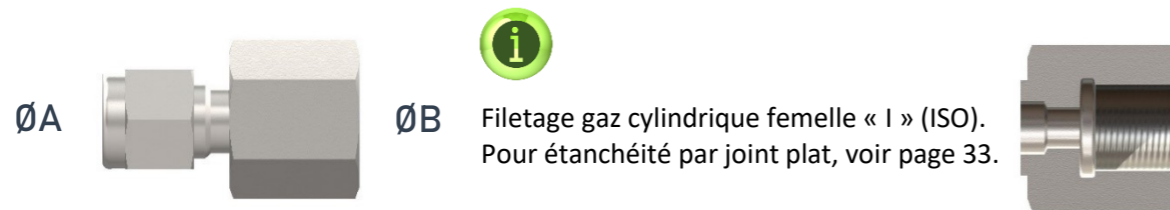

	ØA (mm)	ØB Filetage	Référence article
Dimensions métriques	6	1/4"	10 20 0654
		3/8"	10 20 0656
		1/2"	10 20 0657
	8	1/4"	10 20 0854
		3/8"	10 20 0856
		1/2"	10 20 0857
	10	1/4"	10 20 1054
		3/8"	10 20 1056
		1/2"	10 20 1057
12	1/4"	10 20 1254	
	3/8"	10 20 1256	
	1/2"	10 20 1257	

	ØA (pouce)	ØB Filetage	Référence article
Dimensions fractionnaires	1/4"	1/4"	10 20 5454
		3/8"	10 20 5456
		1/2"	10 20 5457
	5/16"	1/4"	10 20 5554
		1/2"	10 20 5557
		3/8"	10 20 5654
	3/8"	3/8"	10 20 5656
		1/2"	10 20 5657
		1/2"	10 20 5754
1/2"	3/8"	10 20 5756	
	1/2"	10 20 5757	

10 21 Connecteur femelle cylindrique « E »

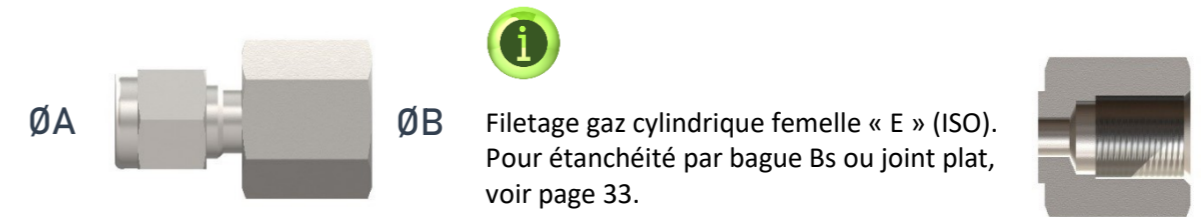

	ØA (mm)	ØB Filetage	Référence article
Dimensions métriques	6	1/8"	10 21 0652
		1/4"	10 21 0654
	22	3/4"	10 21 2259
	25	1"	10 21 2561

10 22 Connecteur femelle cylindrique « M » (manomètre)

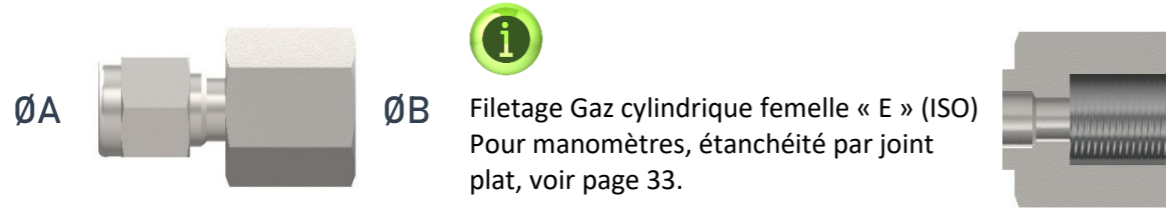

	ØA (mm)	ØB Filetage	Référence article	ØA (pouce)	ØB Filetage	Référence article	
	Dimensions métriques	3	1/4"	10 22 0354	1/8"	1/4"	10 22 5254
6			1/8"	10 22 0652	1/4"	1/8"	10 22 5452
			1/4"	10 22 0654		1/4"	10 22 5454
			3/8"	10 22 0656		3/8"	10 22 5456
			1/2"	10 22 0657		1/2"	10 22 5457
8			1/4"	10 22 0854	5/16"	1/4"	10 22 5554
			3/8"	10 22 0856		1/2"	10 22 5557
			1/2"	10 22 0857		3/8"	1/4"
10			1/4"	10 22 1054	3/8"		10 22 5656
			3/8"	10 22 1056	1/2"		10 22 5657
		1/2"	10 22 1057	1/2"	3/8"	10 22 5756	
12		1/4"	10 22 1254		1/2"	10 22 5757	
		3/8"	10 22 1256				
20		1/2"	10 22 2057				
	22	1/2"	10 22 2257				

10 23 Connecteur femelle NPT passage cloison



	ØA	ØB Filetage	Référence article
Dimensions métriques	6	1/4"	10 23 0654
	12	1/2"	10 23 1257
Dimensions fractionnaires	1/8"	1/8"	10 23 5252
	1/4"	1/8"	10 23 5452
		1/4"	10 23 5454
	3/8"	1/4"	10 23 5654
	1/2"	3/8"	10 23 5756
		1/2"	10 23 5757

REDUCTEURS

10 24 Réducteur métrique

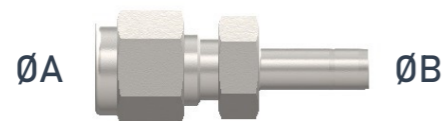

Dimensions métriques	ØA (mm)	ØB	Référence article
	2	3	4
6			10 24 0304
3	6	10	10 24 0306
		12	10 24 0310
4	6	8	10 24 0406
		10	10 24 0603
6	3	8	10 24 0608
		10	10 24 0610
		12	10 24 0612
8	6	18	10 24 0618
		10	10 24 0806
		12	10 24 0810
10	6	12	10 24 0812
		15	10 24 1006
		18	10 24 1008
12	6	12	10 24 1012
		15	10 24 1015
		18	10 24 1018
		8	10 24 1206
		10	10 24 1208
		12	10 24 1210
16	6	16	10 24 1216
		18	10 24 1218
		20	10 24 1220
		22	10 24 1222
		25	10 24 1225
18	6	12	10 24 1612
		16	10 24 1812
		16	10 24 1816
		20	10 24 1820
		22	10 24 1822
25	10 24 1825		

Dimensions métriques	ØA (mm)	ØB	Référence article
	20	20	16
18			10 24 2018
22			10 24 2022
25			10 24 2025
22	22	18	10 24 2218
		20	10 24 2220
		25	10 24 2225
25	25	18	10 24 2518
		20	10 24 2520

10 25 Réducteur fractionnaire

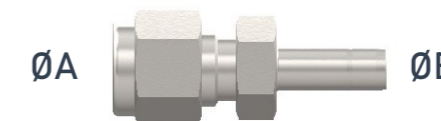

Dimensions fractionnaires	ØA (pouce)	ØB (pouce)	Référence article
	1/16"	1/16"	1/8"
1/4"			10 25 5154
1/8"	1/8"	1/16"	10 25 5251
		1/8"	10 25 5252
		3/16"	10 25 5253
		1/4"	10 25 5254
		3/8"	10 25 5256
		1/2"	10 25 5257
3/16"	3/16"	1/8"	10 25 5352
		1/4"	10 25 5354
1/4"	1/4"	1/8"	10 25 5452
		3/16"	10 25 5453
		1/4"	10 25 5454
		5/16"	10 25 5455
		3/8"	10 25 5456
		1/2"	10 25 5457
		5/8"	10 25 5458
3/4"	10 25 5459		
5/16"	5/16"	3/8"	10 25 5556
		1/2"	10 25 5557
		1/4"	10 25 5654
		3/8"	10 25 5656
		1/2"	10 25 5657
3/8"	3/8"	5/8"	10 25 5658
		3/4"	10 25 5659
		1/4"	10 25 5754
		3/8"	10 25 5756
1/2"	1/2"	1/2"	10 25 5757
		5/8"	10 25 5758
		3/4"	10 25 5759
		1"	10 25 5761

Dimensions fractionnaires	ØA (pouce)	ØB (pouce)	Référence article
	5/8"	5/8"	3/4"
7/8"			10 25 5860
3/4"	3/4"	1"	10 25 5861
		1/2"	10 25 5957
1"	1"	1"	10 25 5961
		1"1/4"	10 25 6163
		1"1/2"	10 25 6164
1"1/4"	1"1/4"	2"	10 25 6165
		1"1/2"	10 25 6364
1"1/2"	1"1/2"	2"	10 25 6365
		2"	10 25 6465

10 26 Réducteur métrique à fractionnaire

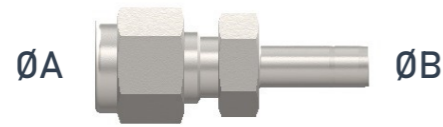

	ØA (mm)	ØB (pouce)	Référence article
Dimensions métriques à fractionnaires	2	1/8"	10 26 0252
	3	1/8"	10 26 0352
		1/4"	10 26 0354
	4	1/4"	10 26 0454
		1/8"	10 26 0652
	6	1/4"	10 26 0654
		5/16"	10 26 0655
		3/8"	10 26 0656
		1/2"	10 26 0657
	8	1/4"	10 26 0854
		3/8"	10 26 0856
		1/2"	10 26 0857
	10	3/8"	10 26 1056
		1/2"	10 26 1057
	12	1/2"	10 26 1257
		3/4"	10 26 1259
18	3/4"	10 26 1859	
	1"	10 26 1861	
25	1"	10 26 2561	

10 28 Réducteur passage de cloison



	ØA (pouce)	ØB (pouce)	Référence article
Dimensions fractionnaires	1/8"	1/8"	10 28 5252
	1/4"	1/4"	10 28 5454
	3/8"	3/8"	10 28 5656
	1/2"	1/2"	10 28 5757
	5/8"	5/8"	10 28 5858
	3/4"	3/4"	10 28 5959
	1"	1"	10 28 6161

10 27 Réducteur fractionnaire à métrique

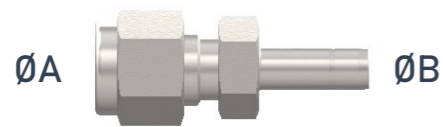

	ØA (pouce)	ØB (mm)	Référence article
Dimensions fractionnaires à métriques	1/8"	6	10 27 5206

EMBOUTS ET BOUCHONS

10 29 Embout de raccordement



	ØA (mm)	Référence article
Dimensions métriques	3	10 29 0303
	6	10 29 0606
	8	10 29 0808
	10	10 29 1010
	12	10 29 1212
	15	10 29 1515
	16	10 29 1616
	18	10 29 1818
	20	10 29 2020
	25	10 29 2525
	28	10 29 2828
	30	10 29 3030
	32	10 29 3232
38	10 29 3838	

	ØA (pouce)	Référence article
Dimensions fractionnaires	1/16"	10 29 5151
	1/8"	10 29 5252
	1/4"	10 29 5454
	5/16"	10 29 5555
	3/8"	10 29 5656
	1/2"	10 29 5757
	5/8"	10 29 5858
	3/4"	10 29 5959
	1"	10 29 6161
	1"1/4	10 29 6363
	1"1/2	10 29 6464
	2"	10 29 6565

10 30 Embout de raccordement réducteur



	ØA (mm)	ØB (mm)	Référence article
Dimensions métriques	6	3	10 30 0603
	8	6	10 30 0806
	10	6	10 30 1006
		8	10 30 1008
	12	6	10 30 1206
		8	10 30 1208
		10	10 30 1210
	16	12	10 30 1612
	28	25	10 30 2825
	32	25	10 30 3225
	38	25	10 30 3825

	ØA (pouce)	ØB (pouce)	Référence article
Dimensions fractionnaires	1/8"	1/16"	10 30 5251
	1/4"	1/16"	10 30 5451
		1/8"	10 30 5452
	3/8"	1/8"	10 30 5652
		1/4"	10 30 5654
	1/2"	1/4"	10 30 5754
		3/8"	10 30 5756
	3/4"	1/2"	10 30 5957
	1"	1/2"	10 30 6157
		3/4"	10 30 6159

10 31 Capuchon



	ØA (mm)	Référence article
Dimensions métriques	2	10 31 0202
	3	10 31 0303
	4	10 31 0404
	6	10 31 0606
	8	10 31 0808
	10	10 31 1010
	12	10 31 1212
	14	10 31 1414
	15	10 31 1515
	16	10 31 1616
	18	10 31 1818
	20	10 31 2020
	22	10 31 2222
	25	10 31 2525
	28	10 31 2828
	30	10 31 3030
32	10 31 3232	
38	10 31 3838	

	ØA (pouce)	Référence article
Dimensions fractionnaires	1/16"	10 31 5151
	1/8"	10 31 5252
	3/16"	10 31 5353
	1/4"	10 31 5454
	5/16"	10 31 5555
	3/8"	10 31 5656
	1/2"	10 31 5757
	5/8"	10 31 5858
	3/4"	10 31 5959
	7/8"	10 31 6060
	1"	10 31 6161
	1"1/8"	10 31 6262
	1"1/4"	10 31 6363
	1"1/2"	10 31 6464
	2"	10 31 6565

10 32 Bouchon

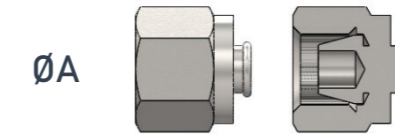

	ØA (mm)	Référence article
Dimensions métriques	2	10 32 0202
	3	10 32 0303
	4	10 32 0404
	6	10 32 0606
	8	10 32 0808
	10	10 32 1010
	12	10 32 1212
	15	10 32 1515
	16	10 32 1616
	18	10 32 1818
	20	10 32 2020
	22	10 32 2222
	25	10 32 2525
	28	10 32 2828
	30	10 32 3030
	32	10 32 3232
	38	10 32 3838

	ØA (pouce)	Référence article
Dimensions fractionnaires	1/16"	10 32 5151
	1/8"	10 32 5252
	3/16"	10 32 5353
	1/4"	10 32 5454
	5/16"	10 32 5555
	3/8"	10 32 5656
	1/2"	10 32 5757
	5/8"	10 32 5858
	3/4"	10 32 5959
	7/8"	10 32 6060
	1"	10 32 6161
	1"1/4"	10 32 6363
	1"1/2"	10 32 6464
	2"	10 32 6565

10 33 Event



	ØA (pouce)	Référence article
Dimensions fractionnaires	1/8"	10 33 5252
	1/4"	10 33 5454
	3/8"	10 33 5656
	1/2"	10 33 5757
	3/4"	10 33 5959

COUDES 90°

10 34 Coude 90° union

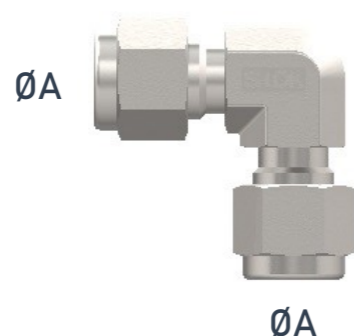

	ØA (mm)	Référence article
Dimensions métriques	3	10 34 0303
	4	10 34 0404
	6	10 34 0606
	8	10 34 0808
	10	10 34 1010
	12	10 34 1212
	14	10 34 1414
	15	10 34 1515
	16	10 34 1616
	18	10 34 1818
	20	10 34 2020
	22	10 34 2222
	25	10 34 2525
	28	10 34 2828
	30	10 34 3030
	32	10 34 3232
38	10 34 3838	
50	10 34 5050	

	ØA (pouce)	Référence article
Dimensions fractionnaires	1/16"	10 34 5151
	1/8"	10 34 5252
	3/16"	10 34 5353
	1/4"	10 34 5454
	5/16"	10 34 5555
	3/8"	10 34 5656
	1/2"	10 34 5757
	5/8"	10 34 5858
	3/4"	10 34 5959
	7/8"	10 34 6060
	1"	10 34 6161
	1"1/8"	10 34 6262
	1"1/4"	10 34 6363
	1"1/2"	10 34 6464
2"	10 34 6565	

10 35 Coude 90° métrique NPT mâle

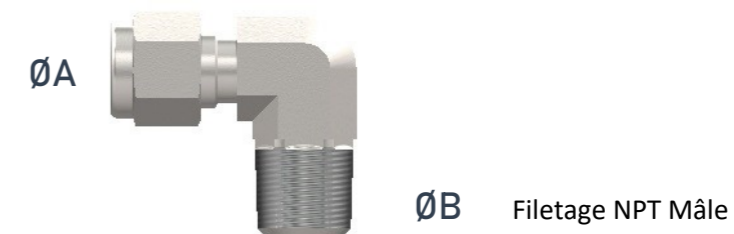

	ØA (mm)	ØB Filetage	Référence article
Dimensions métriques	3	1/8"	10 35 0352
		1/4"	10 35 0354
	4	1/8"	10 35 0452
		1/4"	10 35 0454
	6	1/8"	10 35 0652
		1/4"	10 35 0654
		3/8"	10 35 0656
		1/2"	10 35 0657
	8	1/8"	10 35 0852
		1/4"	10 35 0854
		3/8"	10 35 0856
		1/2"	10 35 0857
	10	1/8"	10 35 1052
		1/4"	10 35 1054
		3/8"	10 35 1056
		1/2"	10 35 1057
	12	1/4"	10 35 1254
		3/8"	10 35 1256
		1/2"	10 35 1257
		3/4"	10 35 1259

	ØA (mm)	ØB Filetage	Référence article
Dimensions métriques	15	1/2"	10 35 1557
		3/8"	10 35 1656
	16	1/2"	10 35 1657
		3/4"	10 35 1659
	18	1/2"	10 35 1857
		3/4"	10 35 1859
	20	1/2"	10 35 2057
		3/4"	10 35 2059
	22	3/4"	10 35 2259
		1"	10 35 2261
	25	3/4"	10 35 2559
		1"	10 35 2561
	30	1"1/4"	10 35 3063
	32	1"1/4"	10 35 3263
	38	1"1/2"	10 35 3864

10 35 Coude 90° fractionnaire NPT mâle

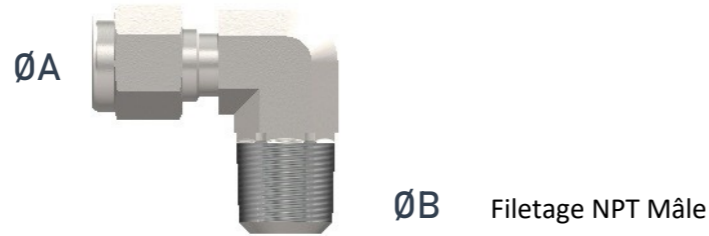

	ØA (pouce)	ØB Filetage	Référence article
Dimensions fractionnaires	1/16"	1/16"	10 35 5151
		1/8"	10 35 5152
	1/8"	1/16"	10 35 5251
		1/8"	10 35 5252
		1/4"	10 35 5254
	3/16"	1/8"	10 35 5352
		1/4"	10 35 5354
	1/4"	1/16"	10 35 5451
		1/8"	10 35 5452
		1/4"	10 35 5454
		3/8"	10 35 5456
		1/2"	10 35 5457
	5/16"	1/8"	10 35 5552
		1/4"	10 35 5554
		3/8"	10 35 5556
	3/8"	1/8"	10 35 5652
		1/4"	10 35 5654
		3/8"	10 35 5656
		1/2"	10 35 5657
		3/4"	10 35 5659

	ØA (pouce)	ØB Filetage	Référence article
Dimensions fractionnaires	1/2"	1/4"	10 35 5754
		3/8"	10 35 5756
		1/2"	10 35 5757
		3/4"	10 35 5759
	5/8"	3/8"	10 35 5856
		1/2"	10 35 5857
		3/4"	10 35 5859
	3/4"	1/2"	10 35 5957
		3/4"	10 35 5959
	7/8"	3/4"	10 35 6059
		1"	10 35 6159
	1"	3/4"	10 35 6159
		1"	10 35 6161
	1"1/4"	1"1/4"	10 35 6363
1"1/2"	1"1/2"	10 35 6464	
2"	2"	10 35 6565	

10 36 Coude 90° mâle Gaz conique



	ØA (mm)	ØB Filetage	Référence article
Dimensions métriques	3	1/8"	10 36 0352
		1/4"	10 36 0354
	4	1/8"	10 36 0452
		1/4"	10 36 0454
	6	1/8"	10 36 0652
		1/4"	10 36 0654
		3/8"	10 36 0656
		1/2"	10 36 0657
	8	1/8"	10 36 0852
		1/4"	10 36 0854
		3/8"	10 36 0856
		1/2"	10 36 0857
	10	1/4"	10 36 1054
		3/8"	10 36 1056
		1/2"	10 36 1057
	12	1/8"	10 36 1252
		1/4"	10 36 1254
		3/8"	10 36 1256
		1/2"	10 36 1257
		3/4"	10 36 1259
	14	1/2"	10 36 1457
	15	1/2"	10 36 1557
	16	3/8"	10 36 1656
		1/2"	10 36 1657
	18	1/2"	10 36 1857
		3/4"	10 36 1859

	ØA	ØB Filetage	Référence article
Dimensions métriques	20	1/2"	10 36 2057
		3/4"	10 36 2059
	22	3/4"	10 36 2259
		1"	10 36 2261
	25	3/4"	10 36 2559
1"		10 36 2561	
28	1"	10 36 2861	
Dimensions fractionnaires	1/8"	1/8"	10 36 5252
		1/4"	10 36 5254
	1/4"	1/8"	10 36 5452
		1/4"	10 36 5454
		3/8"	10 36 5456
	5/16"	1/2"	10 36 5457
		1/4"	10 36 5554
	3/8"	1/8"	10 36 5652
		1/4"	10 36 5654
	1/2"	3/8"	10 36 5656
		1/4"	10 36 5754
		3/8"	10 36 5756
	3/4"	1/2"	10 36 5757
		1/2"	10 36 5957
	1"	1"	10 36 6161

10 37 Coude 90° mâle réducteur

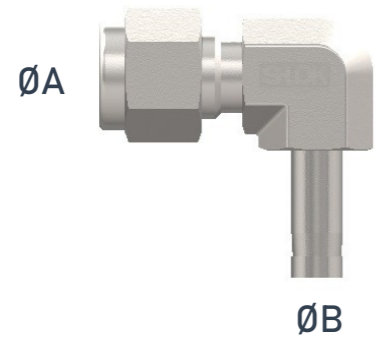

	ØA (mm)	ØB (mm)	Référence article
Métr.	6	6	10 37 0606
	12	12	10 37 1212

10 38 Coude 90° mâle PR

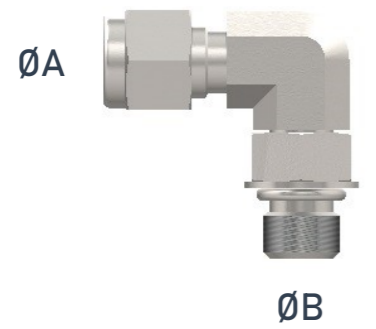

Composants sur demande

10 39 Coude 90° mâle ST

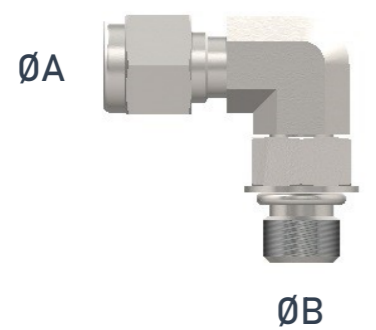

Composants sur demande

10 40 Coude 90° femelle NPT

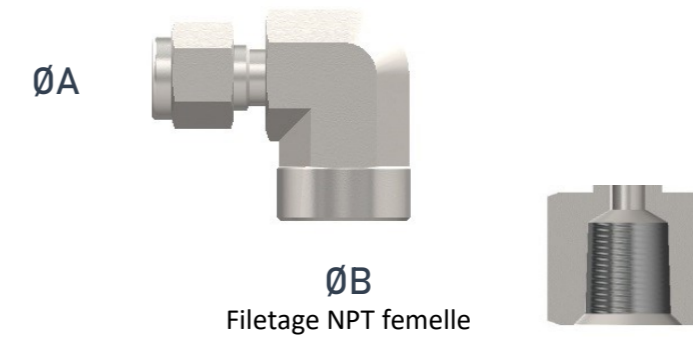

	ØA (mm)	ØB Filetage	Référence article
Dimensions métriques	6	1/8"	10 40 0652
		1/4"	10 40 0654
		1/2"	10 40 0657
	8	1/4"	10 40 0854
		1/8"	10 40 1052
	10	1/4"	10 40 1054
1/8"		10 40 1254	
1/2"		10 40 1257	
16	1/2"	10 40 1657	

	ØA (pouce)	ØB Filetage	Référence article
Dimensions fractionnaires	1/8"	1/8"	10 40 5252
		1/4"	10 40 5254
	3/16"	1/8"	10 40 5352
		1/4"	10 40 5452
	1/4"	1/4"	10 40 5454
		3/8"	10 40 5456
		1/2"	10 40 5457
	5/16"	1/8"	10 40 5552
		1/4"	10 40 5554
	3/8"	1/8"	10 40 5652
		1/4"	10 40 5654
		3/8"	10 40 5656
		1/2"	10 40 5657
	1/2"	1/4"	10 40 5754
		3/8"	10 40 5756
		1/2"	10 40 5757
	5/8"	3/8"	10 40 5856
		1/2"	10 40 5857
	3/4"	1/2"	10 40 5957
		3/4"	10 40 5959
7/8"	3/4"	10 40 6059	
	3/4"	10 40 6159	
1"	3/4"	10 40 6159	
	1"	10 40 6161	

COUDES 90° A SOUDER

10 41 Coude 90° à souder tube OD SW

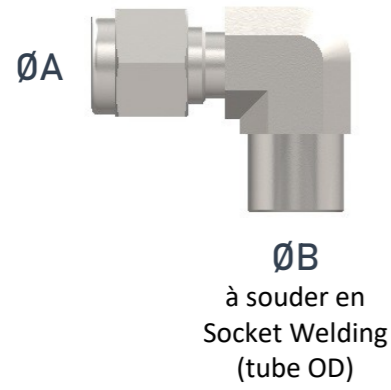

	ØA (pouce)	ØB à souder tube OD SW	Référence article
Dimensions fractionnaires	1/4"	1/4"	10 41 5454
	3/8"	3/8"	10 41 5656
	1/2"	1/2"	10 41 5757
	3/4"	3/4"	10 41 5959
	1"	1"	10 41 6161

10 42 Coude 90° à souder pipe BW

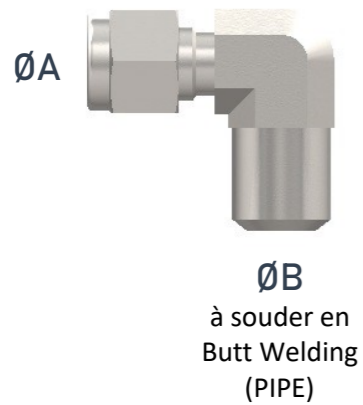

	ØA (pouce)	ØB à souder pipe BW	Référence article
Dimensions fractionnaires	1/4"	1/8"	10 42 5452
		1/4"	10 42 5454
	3/8"	1/4"	10 42 5654
	1/2"	1/2"	10 42 5757
	3/4"	3/4"	10 42 5959

COUDES 45°

10 43 Coude 45° mâle NPT

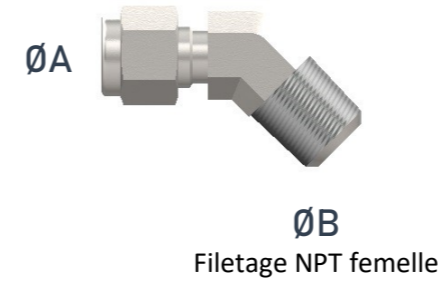

	ØA (pouce)	ØB Filetage	Référence article
1/4"	1/4"	1/8"	10 43 5452
		1/4"	10 43 5454
3/8"	3/8"	1/8"	10 43 5652
		1/4"	10 43 5654
		3/8"	10 43 5656
1/2"	1/2"	3/8"	10 43 5756
		1/2"	10 43 5757
3/4"	3/4"	10 43 5959	
1"	1"	10 43 6161	

10 44 Coude 45° mâle SAE/MS

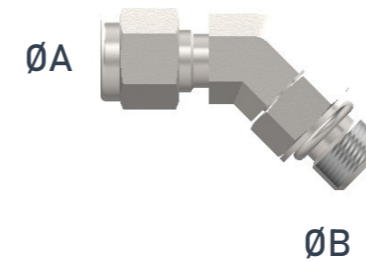

Composants sur demande

TES

10 45 Té union

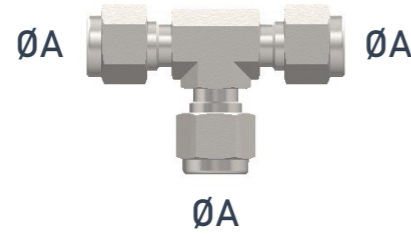

	ØA (mm)	Référence article
Dimensions métriques	2	10 45 0202
	3	10 45 0303
	4	10 45 0404
	6	10 45 0606
	8	10 45 0808
	10	10 45 1010
	12	10 45 1212
	14	10 45 1414
	15	10 45 1515
	16	10 45 1616
	18	10 45 1818
	20	10 45 2020
	22	10 45 2222
	25	10 45 2525
	28	10 45 2828
	30	10 45 3030
32	10 45 3232	
38	10 45 3838	
50	10 45 5050	

	ØA (pouce)	Référence article
Dimensions fractionnaires	1/16"	10 45 5151
	1/8"	10 45 5252
	3/16"	10 45 5353
	1/4"	10 45 5454
	5/16"	10 45 5555
	3/8"	10 45 5656
	1/2"	10 45 5757
	5/8"	10 45 5858
	3/4"	10 45 5959
	7/8"	10 45 6060
	1"	10 45 6161
	1"1/8"	10 45 6262
	1"1/4"	10 45 6363
	1"1/2"	10 45 6464
2"	10 45 6565	

10 46 Té réducteur métrique

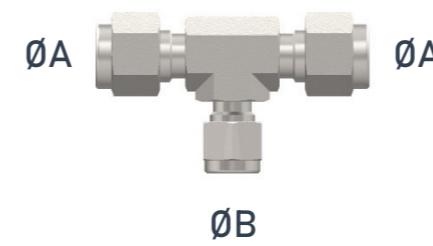

	ØA (mm)	ØB (mm)	Référence article
Dimensions métriques	3	6	10 46 0306
	8	6	10 46 0806
	10	6	10 46 1006
	12	6	10 46 1206
	15	12	10 46 1512
	16	12	10 46 1612
	18	12	10 46 1812
	22	12	10 46 2212
25	12	10 46 2512	

10 47 Té réducteur fractionnaire

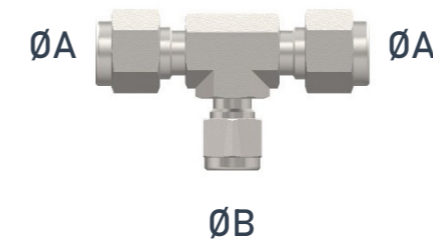

	ØA (pouce)	ØB (pouce)	Référence article
Dimensions fractionnaires	3/8"	1/4"	10 47 5654
	1/2"	1/4"	10 47 5754
		3/8"	10 47 5756
	5/8"	3/8"	10 47 5856
		3/8"	10 47 5956
	3/4"	1/2"	10 47 5957
		3/8"	10 47 6156
		1/2"	10 47 6157
	1"	3/4"	10 47 6159
		1"	10 47 6361
		1"	10 47 6461
	2"	1"	10 47 6561

10 48 Té réducteur spécial

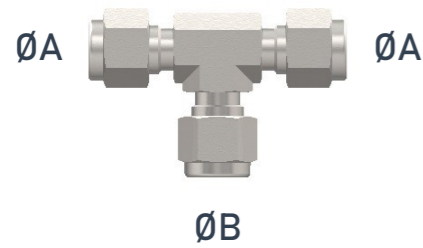

Composant sur demande

10 49 Té NPT mâle

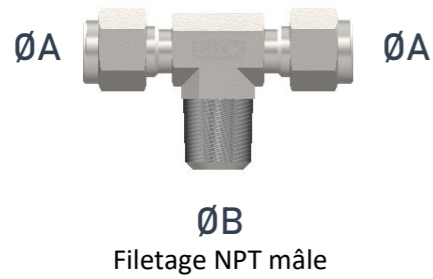

	ØA (mm)	ØB Filetage	Référence article
Dimensions métriques	6	1/8"	10 49 0652
		1/4"	10 49 0654
	8	1/8"	10 49 0852
		1/4"	10 49 0854
	10	1/4"	10 49 1054
	12	1/4"	10 49 1254
3/8"		10 49 1256	
1/2"		10 49 1257	
16	1/2"	10 49 1657	
Dimensions fractionnaires	1/8"	1/8"	10 49 5252
		1/4"	10 49 5254
	3/16"	1/8"	10 49 5352
		1/4"	10 49 5452
	1/4"	1/8"	10 49 5452
		1/4"	10 49 5454
	5/16"	1/8"	10 49 5552
	3/8"	1/4"	10 49 5654
		3/8"	10 49 5656
	1/2"	3/8"	10 49 5756
		1/2"	10 49 5757
	5/8"	1/2"	10 49 5857
	3/4"	3/4"	10 49 5959

10 50 Té mâle SAE MS TTR TTS TRT TFT

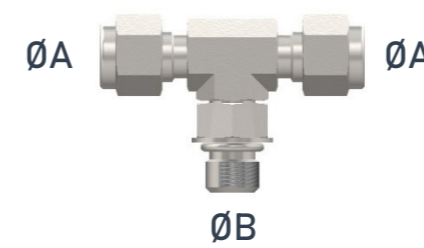

Composants sur demande

10 51 Té femelle NPT

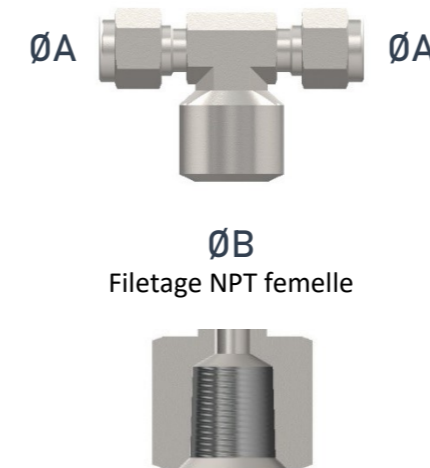

	ØA	ØB Filetage	Référence article
Dimensions métriques	6	1/8"	10 51 0652
		1/4"	10 51 0654
	8	1/8"	10 51 0852
		1/4"	10 51 0854
	10	1/4"	10 51 1054
	12	1/4"	10 51 1254
3/8"		10 51 1256	
1/2"		10 51 1257	
16	1/2"	10 51 1657	
Dimensions fractionnaires	1/8"	1/8"	10 51 5252
		1/4"	10 51 5452
	1/4"	1/8"	10 51 5452
		1/4"	10 51 5454
	3/8"	1/4"	10 51 5654
		3/8"	10 51 5656
		1/2"	10 51 5657
	1/2"	1/4"	10 51 5754
		3/8"	10 51 5756
		1/2"	10 51 5757
	5/8"	1/2"	10 51 5857
	3/4"	3/4"	10 51 5959
		3/4"	10 51 6159
	1"	3/4"	10 51 6159
1"		10 51 6161	

CROIX

10 52 Croix

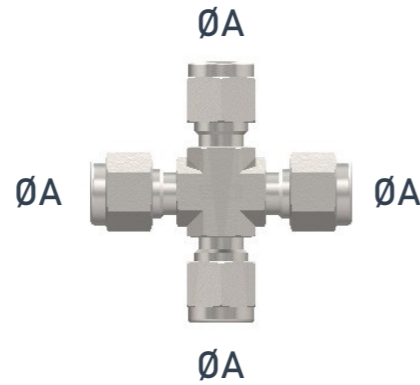

	ØA (mm)	Référence article
Dimensions métriques	3	10 52 0303
	6	10 52 0606
	8	10 52 0808
	10	10 52 1010
	12	10 52 1212
	16	10 52 1616
	18	10 52 1818
	20	10 52 2020
	22	10 52 2222
	25	10 52 2525

	ØA (pouce)	Référence article
Dimensions fractionnaires	1/8"	10 52 5252
	1/4"	10 52 5454
	5/16"	10 52 5555
	3/8"	10 52 5656
	1/2"	10 52 5757
	3/4"	10 52 5959
	1"	10 52 6161

ADAPTEURS MÂLES

10 53 Adaptateur pour tube NPT mâle



	ØA (mm)	ØB Filetage	Référence article
Dimensions métriques	6	1/8"	10 53 0652
		1/4"	10 53 0654
	8	1/4"	10 53 0854
		3/8"	10 53 0856
	10	1/4"	10 53 1054
		3/8"	10 53 1056
		1/2"	10 53 1057
	12	1/4"	10 53 1254
		1/2"	10 53 1257
	28	1"	10 53 2861
		1"1/4	10 53 2863
	30	1"	10 53 3061
		1"1/4	10 53 3063
	32	1"1/4	10 53 3263
	38	1"1/2	10 53 3864

	ØA (pouce)	ØB Filetage	Référence article
Dimensions fractionnaires	1/8"	1/8"	10 53 5252
		1/4"	10 53 5254
	3/16"	1/8"	10 53 5352
		1/4"	10 53 5354
	1/4"	1/8"	10 53 5452
		1/4"	10 53 5454
		3/8"	10 53 5456
	5/16"	1/2"	10 53 5457
		1/8"	10 53 5552
	3/8"	1/4"	10 53 5554
		1/8"	10 53 5652
	1/2"	1/4"	10 53 5654
		3/8"	10 53 5656
		1/2"	10 53 5657
	5/8"	1/4"	10 53 5754
		3/8"	10 53 5756
	3/4"	1/2"	10 53 5757
		1/2"	10 53 5857
	1"	1/2"	10 53 5957
		3/4"	10 53 5959
	1"1/4	3/4"	10 53 6159
		1"	10 53 6161
	1"1/4	1"1/4	10 53 6363
	1"1/2	1"1/2	10 53 6464
	2"	2"	10 53 6565

10 54 Adaptateur pour tube Gaz conique mâle



	ØA (mm)	ØB Filetage	Référence article
Dimensions métriques	6	1/8"	10 54 0652
		1/4"	10 54 0654
	8	1/4"	10 54 0854
	10	1/4"	10 54 1054
		3/8"	10 54 1056
	12	1/4"	10 54 1254
		3/8"	10 54 1256
		1/2"	10 54 1257
	28	1"	10 54 2861
		1"1/4	10 54 2863
	30	1"1/4	10 54 3063
	32	1"1/4	10 54 3263
38	1"1/2	10 54 3864	

	ØA (pouce)	ØB Filetage	Référence article
Dimensions fractionnaires	1/8"	1/8"	10 54 5252
		1/4"	10 54 5254
	1/4"	1/8"	10 54 5452
		1/4"	10 54 5454
	3/8"	1/4"	10 54 5654
		3/8"	10 54 5656
		1/2"	10 54 5657
	1/2"	1/4"	10 54 5754
		3/8"	10 54 5756
		1/2"	10 54 5757
	3/4"	3/4"	10 54 5959
	1"	1"	10 54 6161

10 55 Adaptateur pour tube Gaz cylindrique mâle « S »

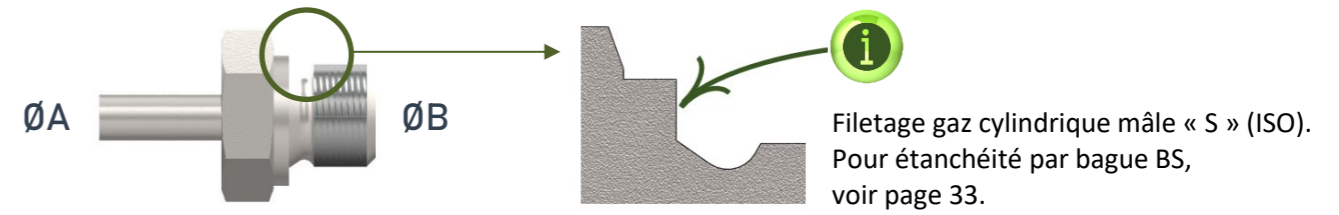

	ØA (mm)	ØB Filetage	Référence article
Dimensions métriques	6	1/8"	10 55 0652
		1/4"	10 55 0654
	8	1/4"	10 55 0854
	10	1/4"	10 55 1054
		3/8"	10 55 1056
	12	1/4"	10 55 1254
		3/8"	10 55 1256
		1/2"	10 55 1257
	28	1"	10 55 2861
		1"1/4	10 55 2863
	30	1"1/4	10 55 3063
	32	1"1/4	10 55 3263
38	1"1/2	10 55 3864	

	ØA (pouce)	ØB Filetage	Référence article
Dimensions fractionnaires	1/8"	1/8"	10 55 5252
		1/4"	10 55 5254
	1/4"	1/8"	10 55 5452
		1/4"	10 55 5454
	3/8"	1/4"	10 55 5654
		3/8"	10 55 5656
		1/2"	10 55 5754
	1/2"	3/8"	10 55 5756
		1/2"	10 55 5757
		3/4"	3/4"
	1"	1"	10 55 6161

10 56 Adaptateur pour tube Gaz cylindrique mâle « E »

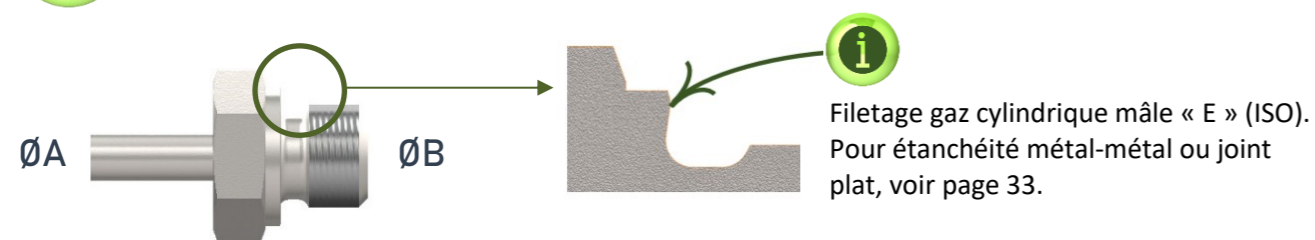

	ØA (mm)	ØB Filetage	Référence article
Dimensions métriques	28	1"	10 56 2861
		1"1/4	10 56 2863
	30	1"1/4	10 56 3063
	32	1"1/4	10 56 3263
	38	1"1/2	10 56 3864

10 57 Adaptateur pour tube ST SAE MS AN mâle



10 58 Adaptateur pour tube mâle à souder

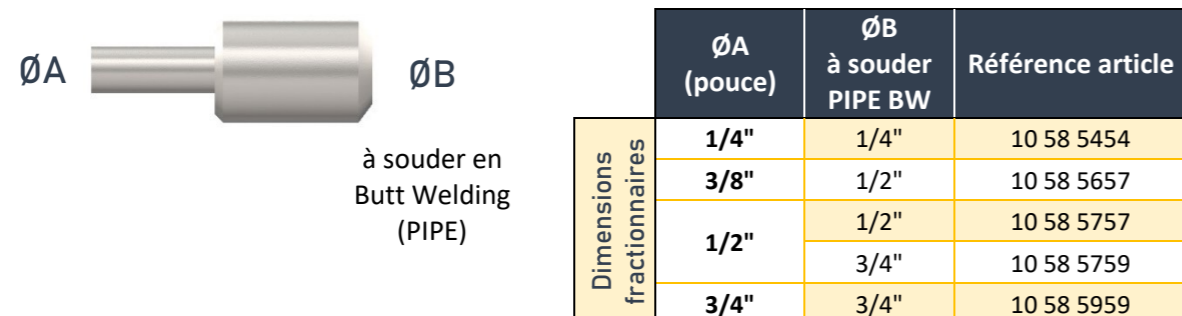

	ØA (pouce)	ØB à souder PIPE BW	Référence article
Dimensions fractionnaires	1/4"	1/4"	10 58 5454
	3/8"	1/2"	10 58 5657
	1/2"	1/2"	10 58 5757
		3/4"	10 58 5759
	3/4"	3/4"	10 58 5959

ADAPTATEURS FEMELLES

10 59 Adaptateur pour tube femelle NPT



	ØA (mm)	ØB Filetage	Référence article
Dimensions métriques	6	1/8"	10 59 0652
		1/4"	10 59 0654
	8	1/4"	10 59 0854
		1/4"	10 59 1054
	10	3/8"	10 59 1056
		1/2"	10 59 1057
12	1/4"	10 59 1254	
	1/2"	10 59 1257	

	ØA (pouce)	ØB Filetage	Référence article
Dimensions fractionnaires	1/8"	1/8"	10 59 5252
		1/4"	10 59 5254
	3/16"	1/4"	10 59 5354
	1/4"	1/8"	10 59 5452
		1/4"	10 59 5454
		3/8"	10 59 5456
	1/2"	1/2"	10 59 5457
		1/4"	10 59 5554
	3/8"	1/8"	10 59 5652
		1/4"	10 59 5654
		3/8"	10 59 5656
		1/2"	10 59 5657
	1/2"	1/4"	10 59 5754
		3/8"	10 59 5756
	5/8"	1/2"	10 59 5757
		1/2"	10 59 5857
	3/4"	1/2"	10 59 5957
		3/4"	10 59 5959
		1"	10 59 5961
	1"	3/4"	10 59 6159
1"		10 59 6161	
1"1/4	1"1/4	10 59 6363	
1"1/2	1"1/2	10 59 6464	
2"	2"	10 59 6565	

10 60 Adaptateur pour tube femelle Gaz conique



	ØA	ØB Filetage	Référence article
Métr.	6	1/8"	10 60 0652
	8	1/4"	10 60 0854
	10	1/4"	10 60 1054
Dimensions fractionnaires	1/4"	1/8"	10 60 5452
		1/4"	10 60 5454
	3/8"	1/4"	10 60 5654
		3/8"	10 60 5656
	1/2"	1/4"	10 60 5754
		3/8"	10 60 5756
	1/2"	10 60 5757	

10 61 Adaptateur pour tube femelle Gaz cylindrique « S »

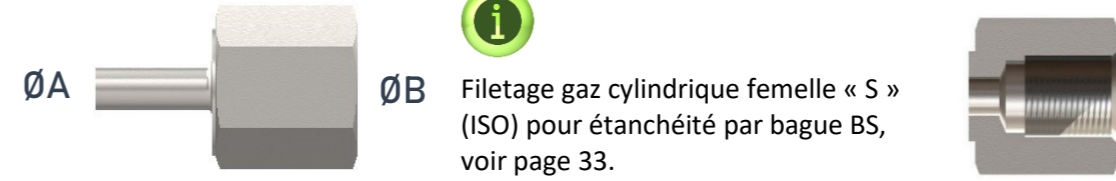

Filetage gaz cylindrique femelle « S » (ISO) pour étanchéité par bague BS, voir page 33.

	ØA	ØB Filetage	Référence article
Métr.	6	1/8"	10 61 0652
		1/4"	10 61 0654
	12	1/2"	10 61 1257
Dimensions fractionnaires	1/8"	1/8"	10 61 5252
	1/4"	1/8"	10 61 5452
		1/4"	10 61 5454
	3/8"	1/4"	10 61 5654
		3/8"	10 61 5656
	1/2"	3/8"	10 61 5756
1/2"		10 61 5757	



10 62 Adaptateur pour tube femelle Gaz cylindrique « M »

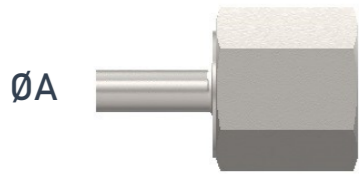

Filetage gaz cylindrique femelle « M » (ISO).
Pour étanchéité par joint plat, voir page 33.

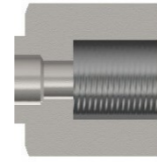

	ØA	ØB Filetage	Référence article
Dimensions métriques	6	1/4"	10 62 0654
		3/8"	10 62 0656
		1/2"	10 62 0657
	8	1/4"	10 62 0854
		3/8"	10 62 0856
		1/2"	10 62 0857
	10	1/4"	10 62 1054
		3/8"	10 62 1056
		1/2"	10 62 1057
	12	1/4"	10 62 1254
		3/8"	10 62 1256
		1/2"	10 62 1257
16	1/2"	10 62 1657	
	1/2"	10 62 1857	
Fract.	1/4"	1/4"	10 62 5454
	3/8"	3/8"	10 62 5656
	1/2"	1/2"	10 62 5757

10 63 Adaptateur pour tube femelle Gaz cylindrique « I »

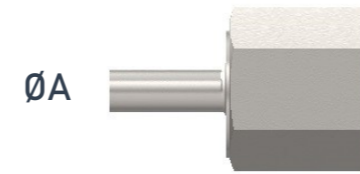

Filetage gaz cylindrique femelle « I » (ISO).
Pour étanchéité par joint plat, voir page 33.

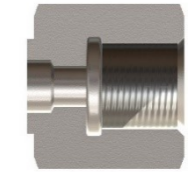

	ØA	ØB Filetage	Référence article
Dimensions métriques	6	1/4"	10 63 0654
		3/8"	10 63 0656
		1/2"	10 63 0657
	8	1/4"	10 63 0854
		3/8"	10 63 0856
		1/2"	10 63 0857
	10	1/4"	10 63 1054
		3/8"	10 63 1056
		1/2"	10 63 1057
	12	1/4"	10 63 1254
		3/8"	10 63 1256
		1/2"	10 63 1257
Fract.	1/4"	1/4"	10 63 5454
	3/8"	3/8"	10 63 5656
	1/2"	1/2"	10 63 5757

10 64 Adaptateur pour tube femelle AN



	ØA (pouce)	ØB AN	Référence article
Dimensions fractionnaires	1/8"	1/8"	10 64 5252
		1/4"	10 64 5254
	1/4"	1/4"	10 64 5454
	3/8"	3/8"	10 64 5656
	1/2"	1/2"	10 64 5757
	3/4"	3/4"	10 64 5959

PIECES DE RECHANGES

10 65 Ecrou



	ØA (mm)	Référence article
Dimensions métriques	2	10 65 0202
	3	10 65 0303
	4	10 65 0404
	6	10 65 0606
	8	10 65 0808
	10	10 65 1010
	12	10 65 1212
	14	10 65 1414
	15	10 65 1515
	16	10 65 1616
	18	10 65 1818
	20	10 65 2020
	22	10 65 2222
	25	10 65 2525
	28	10 65 2828
	30	10 65 3030
	32	10 65 3232
	38	10 65 3838
50	10 65 5050	

	ØA (pouce)	Référence article
Dimensions fractionnaires	1/16"	10 65 5151
	1/8"	10 65 5252
	3/16"	10 65 5353
	1/4"	10 65 5454
	5/16"	10 65 5555
	3/8"	10 65 5656
	1/2"	10 65 5757
	5/8"	10 65 5858
	3/4"	10 65 5959
	7/8"	10 65 6060
	1"	10 65 6161
	1"1/4"	10 65 6363
	1"1/2"	10 65 6464
	2"	10 65 6565

10 66 Ecrou mâle



	ØA (mm)	Référence article
Métr.	10	10 66 1010
	12	10 66 1212

	ØA (pouce)	Référence article
Fract.	1/16"	10 66 5151
	1/8"	10 66 5252
	1/4"	10 66 5454
	1/2"	10 66 5757



10 67

Bague avant

ØA



	ØA (mm)	Référence article
Dimensions métriques	2	10 67 0202
	3	10 67 0303
	4	10 67 0404
	6	10 67 0606
	8	10 67 0808
	10	10 67 1010
	12	10 67 1212
	14	10 67 1414
	15	10 67 1515
	16	10 67 1616
	18	10 67 1818
	20	10 67 2020
	22	10 67 2222
	25	10 67 2525
	28	10 67 2828
	30	10 67 3030
32	10 67 3232	
38	10 67 3838	
50	10 67 5050	

	ØA (pouce)	Référence article
Dimensions fractionnaires	1/16"	10 67 5151
	1/8"	10 67 5252
	3/16"	10 67 5353
	1/4"	10 67 5454
	5/16"	10 67 5555
	3/8"	10 67 5656
	1/2"	10 67 5757
	5/8"	10 67 5858
	3/4"	10 67 5959
	7/8"	10 67 6060
	1"	10 67 6161
	1"1/4	10 67 6363
	1"1/2	10 67 6464
2"	10 67 6565	

10 68

Bague arrière

ØA



	ØA (mm)	Référence article
Dimensions métriques	2	10 68 0202
	3	10 68 0303
	4	10 68 0404
	6	10 68 0606
	8	10 68 0808
	10	10 68 1010
	12	10 68 1212
	14	10 68 1414
	15	10 68 1515
	16	10 68 1616
	18	10 68 1818
	20	10 68 2020
	22	10 68 2222
	25	10 68 2525
	28	10 68 2828
	30	10 68 3030
	32	10 68 3232
	38	10 68 3838
	50	10 68 5050

	ØA (pouce)	Référence article
Dimensions fractionnaires	1/16"	10 68 5151
	1/8"	10 68 5252
	3/16"	10 68 5353
	1/4"	10 68 5454
	5/16"	10 68 5555
	3/8"	10 68 5656
	1/2"	10 68 5757
	5/8"	10 68 5858
	3/4"	10 68 5959
	7/8"	10 68 6060
	1"	10 68 6161
	1"1/4	10 68 6363
	1"1/2	10 68 6464
2"	10 68 6565	

10 69

Kit bague avant + bague arrière



	ØA (mm)	Référence article
Dimensions métriques	2	10 69 0202
	3	10 69 0303
	4	10 69 0404
	6	10 69 0606
	8	10 69 0808
	10	10 69 1010
	12	10 69 1212
	14	10 69 1414
	15	10 69 1515
	16	10 69 1616
	18	10 69 1818
	20	10 69 2020
	22	10 69 2222
	25	10 69 2525
	28	10 69 2828
	30	10 69 3030
32	10 69 3232	
38	10 69 3838	
50	10 69 5050	

	ØA (pouce)	Référence article
Dimensions fractionnaires	1/16"	10 69 5151
	1/8"	10 69 5252
	3/16"	10 69 5353
	1/4"	10 69 5454
	5/16"	10 69 5555
	3/8"	10 69 5656
	1/2"	10 69 5757
	5/8"	10 69 5858
	3/4"	10 69 5959
	7/8"	10 69 6060
	1"	10 69 6161
	1"1/4	10 69 6363
	1"1/2	10 69 6464
	2"	10 69 6565

10 70

Kit écrou + bague avant + bague arrière



	ØA (mm)	Référence article
Dimensions métriques	2	10 70 0202
	3	10 70 0303
	4	10 70 0404
	6	10 70 0606
	8	10 70 0808
	10	10 70 1010
	12	10 70 1212
	14	10 70 1414
	15	10 70 1515
	16	10 70 1616
	18	10 70 1818
	20	10 70 2020
	22	10 70 2222
	25	10 70 2525
	28	10 70 2828
	30	10 70 3030
32	10 70 3232	
38	10 70 3838	
50	10 70 5050	

	ØA (pouce)	Référence article
Dimensions fractionnaires	1/16"	10 70 5151
	1/8"	10 70 5252
	3/16"	10 70 5353
	1/4"	10 70 5454
	5/16"	10 70 5555
	3/8"	10 70 5656
	1/2"	10 70 5757
	5/8"	10 70 5858
	3/4"	10 70 5959
	7/8"	10 70 6060
	1"	10 70 6161
	1"1/4	10 70 6363
	1"1/2	10 70 6464
	2"	10 70 6565



10 71

Joint S / E / M / I



Informations :
Filetages et étanchéités par bague BS ou joints plats
Page : 4



	Désignation	ØA (pouce)	Référence article
Pour raccord de type « S »	BAGUE BS INOX	1/8	10 71 5201
	BAGUE BS INOX	1/4	10 71 5401
	BAGUE BS INOX	3/8	10 71 5601
	BAGUE BS INOX	1/2	10 71 5701
	BAGUE BS INOX	3/4	10 71 5901
	BAGUE BS INOX	1"	10 71 6101



Pour raccord de type « E »	BAGUE CUIVRE « E »	1/8	10 71 5202
	BAGUE CUIVRE « E »	1/4	10 71 5402
	BAGUE CUIVRE « E »	3/8	10 71 5602
	BAGUE CUIVRE « E »	1/2	10 71 5702
	BAGUE CUIVRE « E »	3/4	10 71 5902
	BAGUE CUIVRE « E »	1"	10 71 6102



Pour raccord de type « M »	BAGUE CUIVRE « M »	1/4	10 71 5403
	BAGUE CUIVRE « M »	3/8	10 71 5603
	BAGUE CUIVRE « M »	1/2	10 71 5703



Pour raccord de type « I »	JOINT PLAT « I »	1/4	10 71 5404
	JOINT PLAT « I »	3/8	10 71 5604
	JOINT PLAT « I »	1/2	10 71 5704